

GEEIGNET ZUM REGENERIEREN VON SCHRAUBENGWINDEN ODER
FÜR SEHR STARKES KLOPFEN IN WEICHE MATERIALIEN.

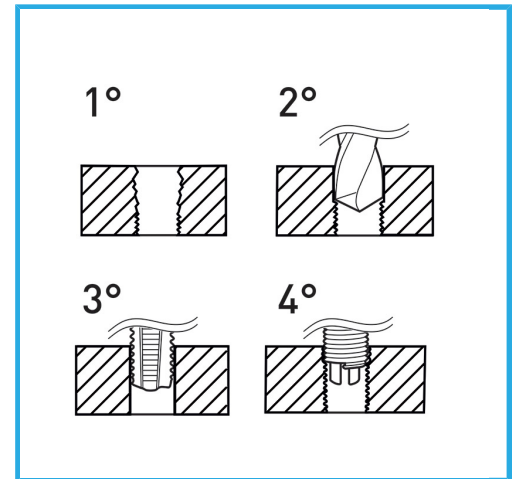

Maße	M6 - M10 mm
Gewindebohrer STI	M6 x 1.0 - M8 x 1.25 - M10 x 1.5
Bohrer	6.3 mm - 8.3 mm - 10.4 mm
Gewindeeinsätze	M6 25 St - M8 25 St - M10 25 St
Montagewerkzeug	3 St g
Brechwerkzeug	3 St g
Verpackungsmaße	240x240x30 h mm
Bruttogewicht	1,47 kg
EAN-Code	8012667362898



Aufhängbar



HSS

-



INOX

-



87 Pcs