

PERMANENT MAGNET MOTOR, METAL FRAME, STRONG CABLE, WITH ANTI UNWINDING DEVICE AND CABLE GUIDE. TO BE USED ONLY FOR HORIZONTAL...

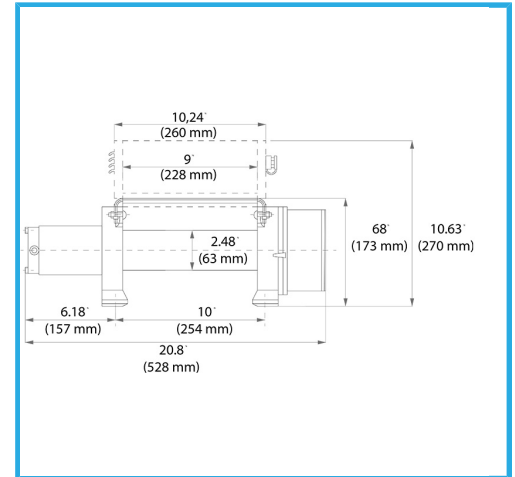

Rated line pull	2720 kg
Speed	1,3 - 4,5 m / min
Motor	12 V 1,3 kW 1,8 hp
Gear Reduction ratio	294:1
Cable size	ø 7,2 mm x 32 m
Drum dimensions	ø 63 x 228 mm
Overall dimensions	520 x 180 x 175h mm
Net weight	29 kg
Gross weight	32,50 kg
EAN Code	8012667213619

