

CON CONEXIÓN DE MANGUITO, RECOMENDADO PARA USO EN MÁQUINAS CON POTENCIA MEDIA.

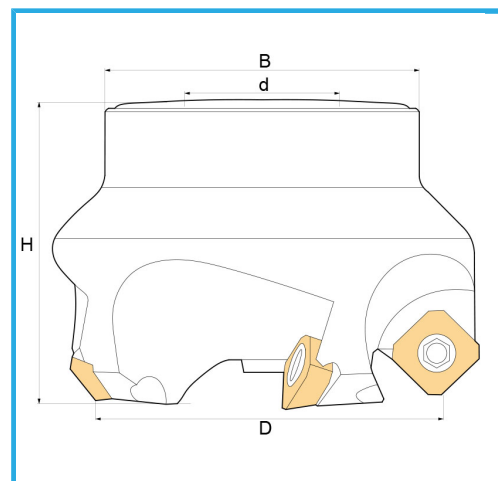

€159,00

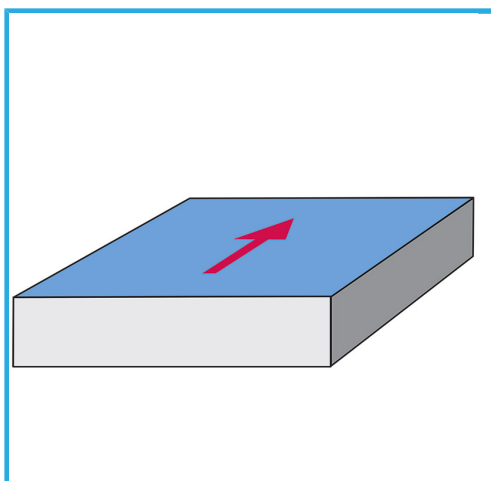

D	63 mm
H	50 mm
B	76 mm
d	22 mm
Z	5
Tornillos	KV500
Paquita (no incluida)	SEHX1204... / SEHT1204...
Peso bruto	0,84 kg
Codigo de barras	8012667182564



Caja



Satinado



Niquelada



Externa